

A NASA Perspective on Electric Propulsion Technologies for Future Generations of Large Commercial Aircraft

Nateri Madavan

Associate Project Manager
NASA Advanced Air Transport Technology Project
NASA Ames Research Center, Moffett Field, California
CEC-ICMC 2017, Madison, Wisconsin, July 9-13, 2017

NASA Vision for the Future of Aviation



- A radical increase in new and cost-effective uses of aviation
- The skies will accommodate thousands of times the number of vehicles flying today
- Travelers will have the flexibility to fly when and where they want in a fraction of the time that it takes today
- All forms of air travel will be as safe as commercial air transport is today
- Subsonic transports will remain the backbone of long-haul global and domestic travel
- Carbon and noise footprints from aviation will be significantly reduced



Global Growth in Commercial Aviation



Tremendous opportunities

- Huge demand
- \$5.9T market over next 20 years
- Need for speed

Enormous Challenges

- Competitiveness
- Environment
- Operations
- Safety

Delivery demand is diverse

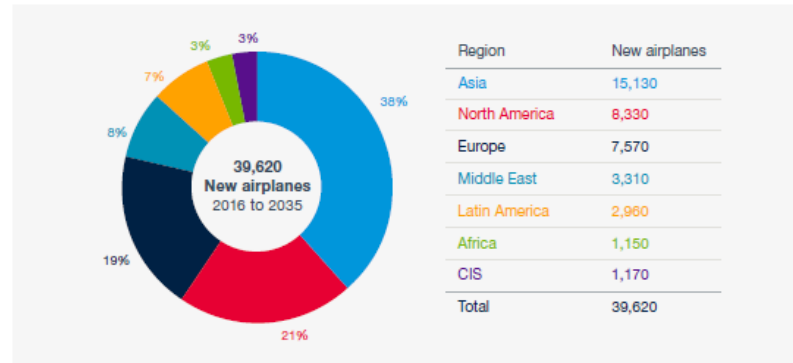

Over 39,000 New Aircraft required (replacement and growth) over the next 20 year period (\$5.9T)

Growth in Airline passenger traffic at annual rate of 4.8%, and Air Cargo traffic at 4.2% over the next 20 years

Air travel becoming more diverse geographically

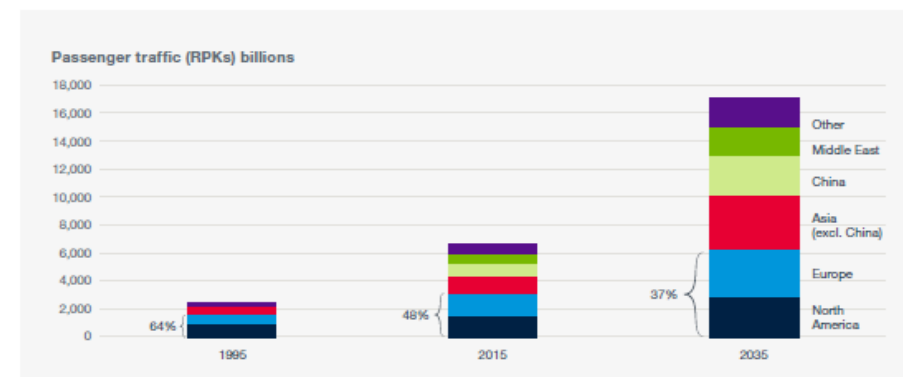

The Aviation Grand Challenge

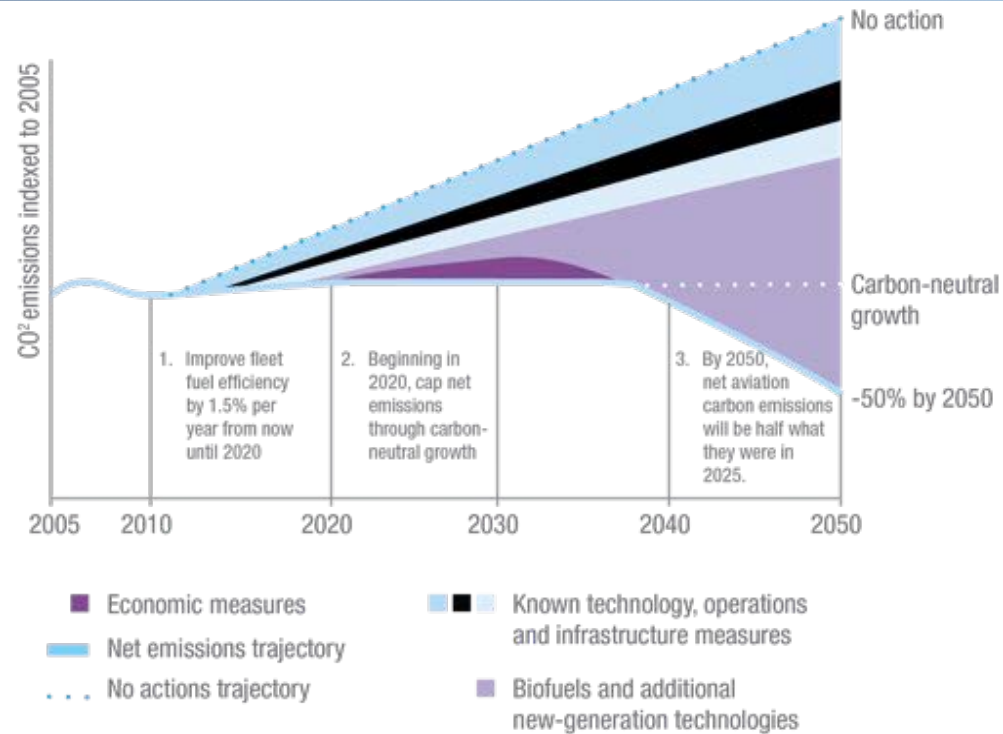

Reduce carbon footprint by 50% by 2050...in the face of increasing demand, while reducing development, manufacturing, and operational costs of aircraft, and meeting landing/takeoff noise and NO_x regulations



Why Focus on Commercial Transports

2012 Fuel Consumption

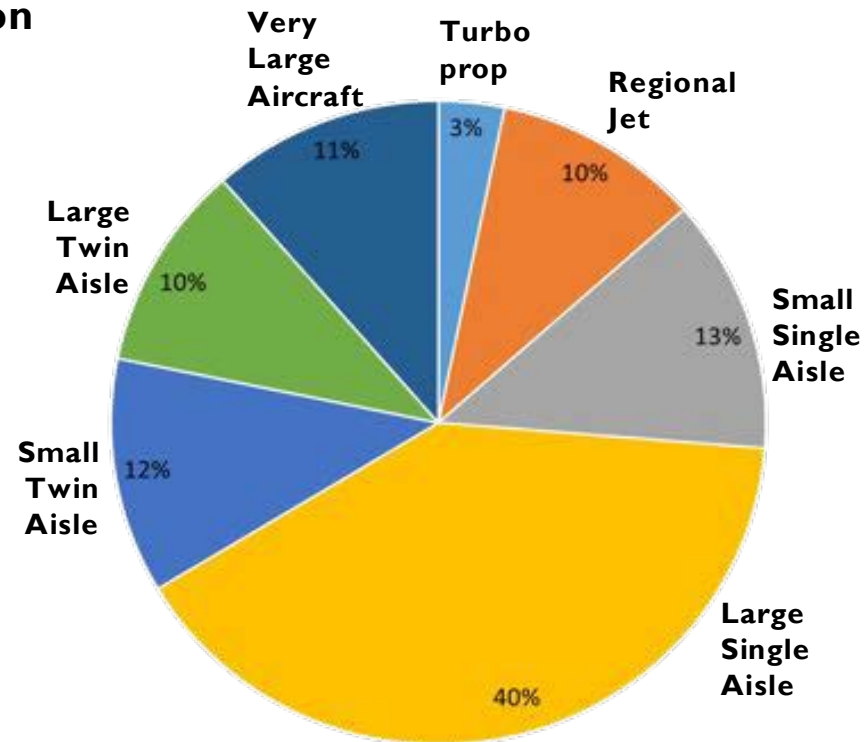

100+ passenger aircraft consumed 87% of fuel!

NASA Perspective on Commercial Aviation Electrification



Explore alternative propulsion systems that can *reduce carbon, noise, and emissions* from commercial aviation

Promise of cleaner, quieter systems

Potential for vehicle system efficiency gains (use less energy)

Leverage advances in other transportation and energy sectors

Address aviation-unique challenges (e.g., weight, altitude)

Recognize potential for early learning and impact on smaller or shorter range aircraft

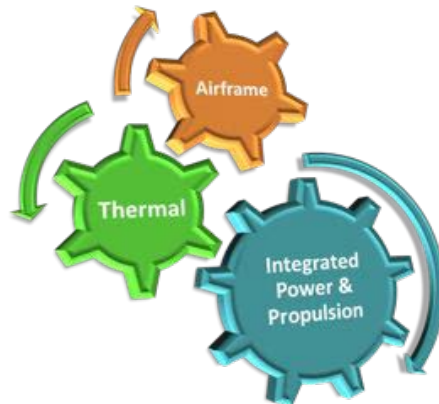

Key Challenges

- Electrical system weight
- Energy storage capabilities
- Thermal management
- Flight controls
- Safety
- Certification



Electric Aircraft Propulsion Architectures

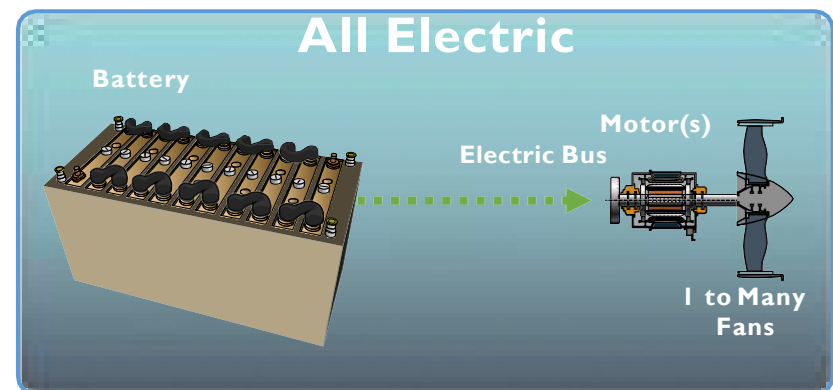
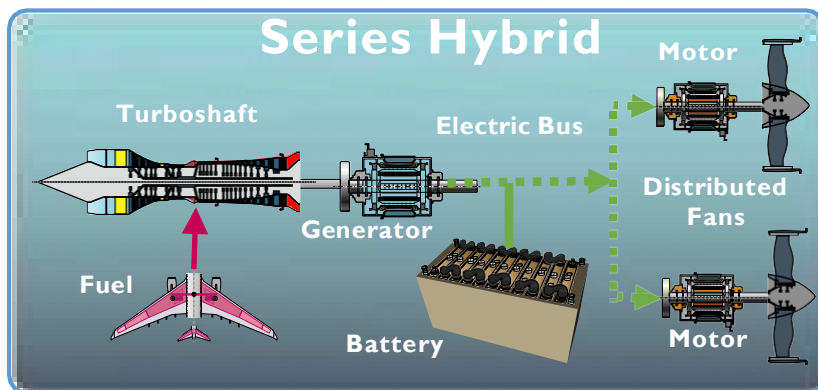
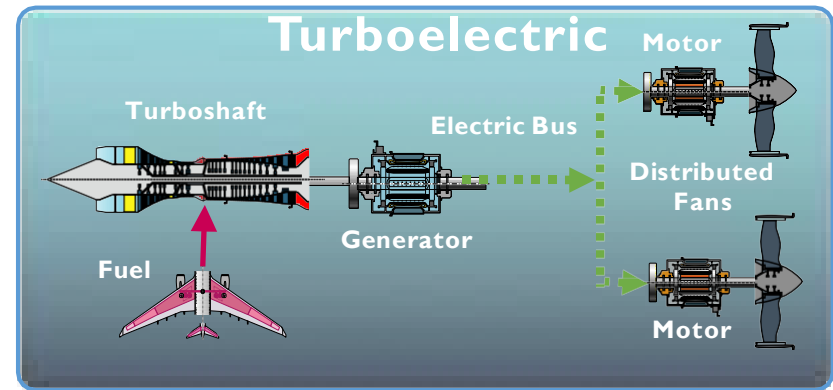
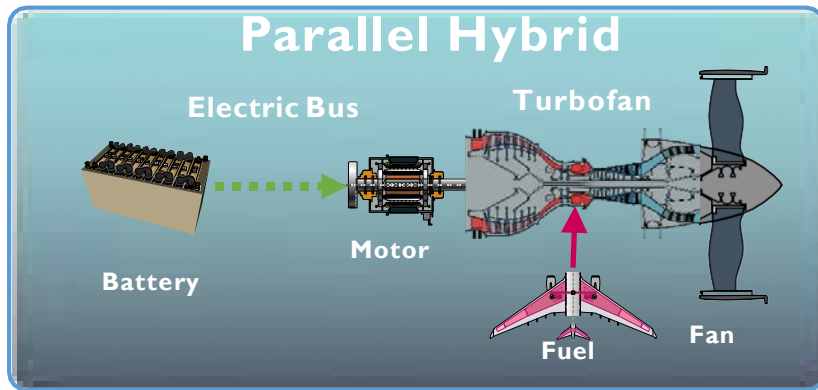

Electric Propulsion Enables Exciting Configuration Options

Flexibility to move power around aircraft and integrate propulsion with airframe

Boundary Layer Ingestion: Allows propulsion systems to energize boundary layers without distorted flow entering turbine core

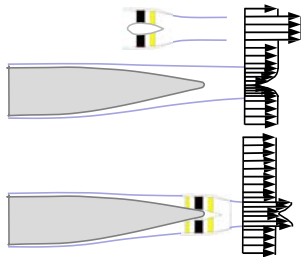

Wing Tip Propulsors: Allows energizing wing tip vortices without penalty of small turbomachinery

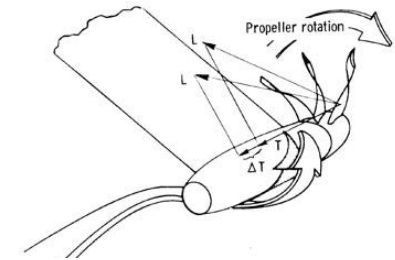

Common Technology Requirement: *Increased efficiency and specific power in electric drive systems, thermal management systems, power extraction, and/or energy storage*

Distributed Propulsion: Allows effective increase in fan bypass ratio through distributed propulsors

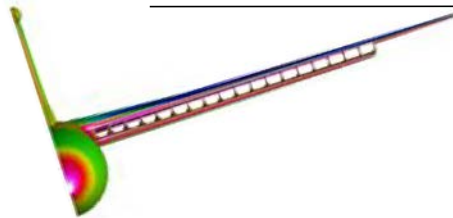

Lower Carbon Designs: Reduces combustion-based propulsive power (and emissions) using electric motors and/or on-board “clean” energy storage

The NASA N3-X Superconducting Concept Aircraft



N3-X is a Technology Collector Design showing future potential of Fully Turboelectric, Distributed Propulsion, and Boundary Layer Ingestion

70% Fuel Burn benefits
(vs. CY2000 baseline)

20% Fuel Burn Benefits
(vs. HWB with ultra high bypass
turbofans)

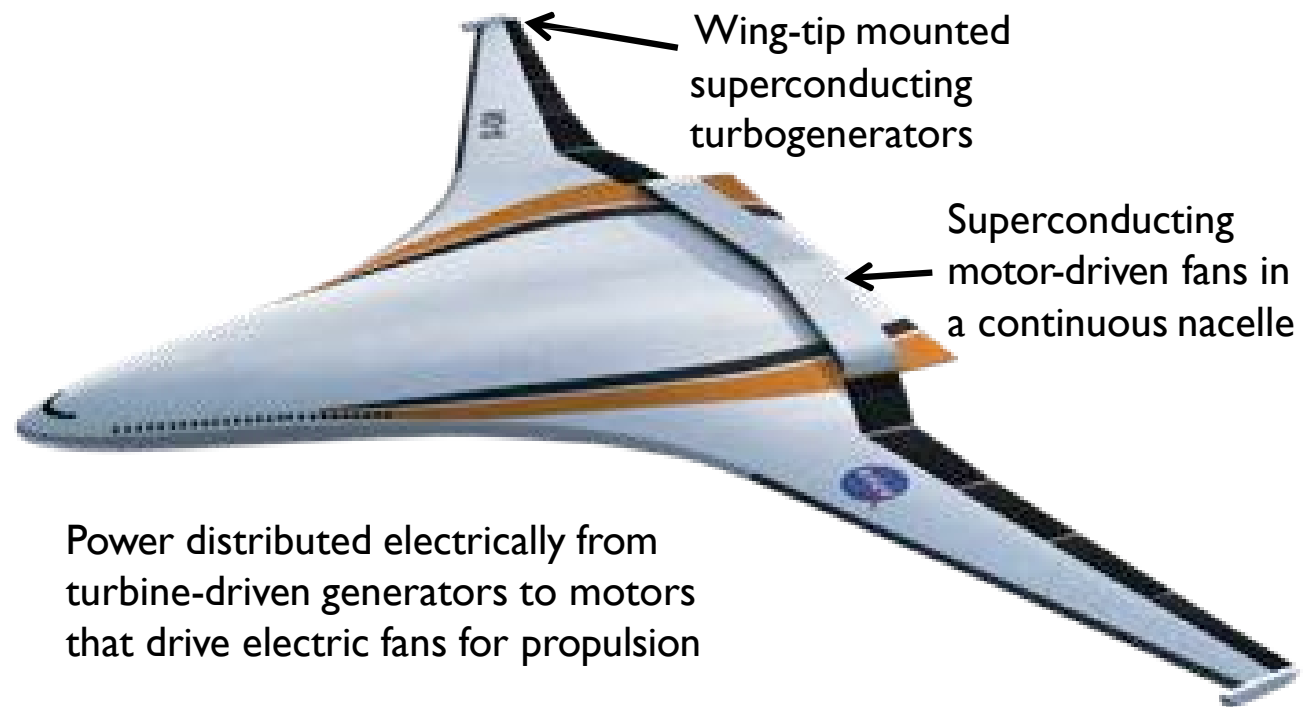

Where Can Cryogenic Systems Take Us?

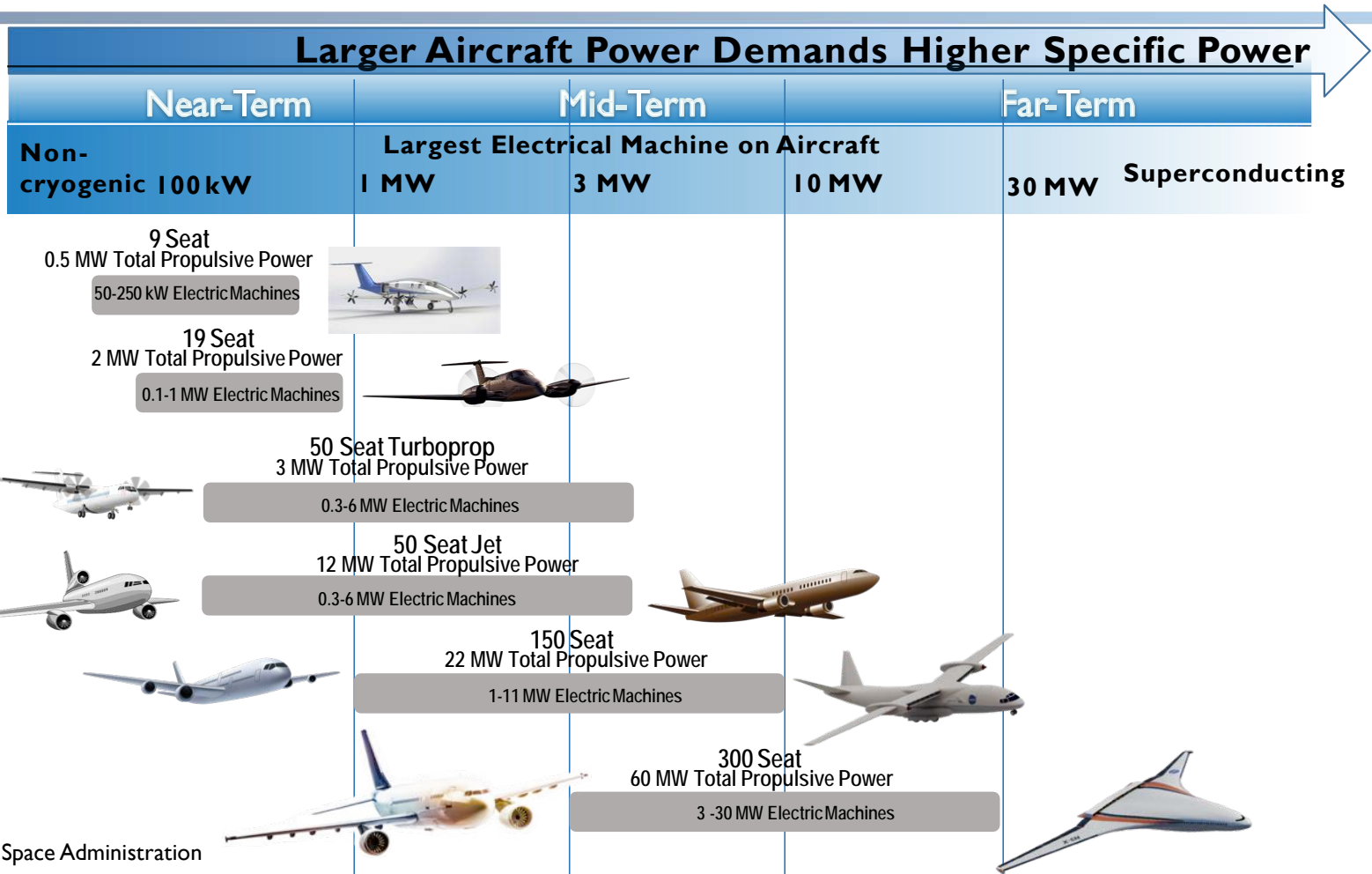

Superconductivity Enables Large Electric Air Vehicles

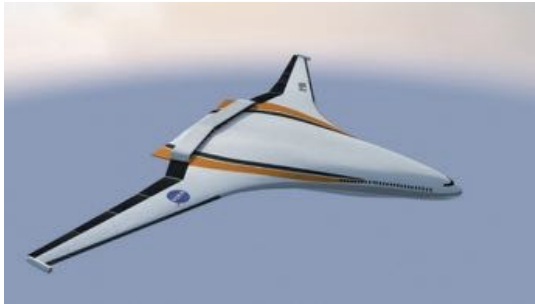

NASA N3-X

- Fully Turboelectric, 300 passenger
- Increased Fan Area, Boundary Layer Ingestion
- Superconducting Power and Transmission
- ~70% Fuel Savings relative to CY2000 baseline
- ~20% Fuel Savings relative to Advanced Hybrid Wing Body Baseline

Airbus/Rolls-Royce E-Thrust

- Fully Turboelectric
- Increased Fan Area, Boundary Layer Ingestion
- Superconducting Power and Transmission



ESAero ECO-150

- Fully Turboelectric, 150 passenger
- Increased Fan Area, High L/D wing
- Both Superconducting and Ambient Temperature versions
- ~60% Fuel Savings Relative to CY2000 Baseline



Cryogenic Powertrain Research

Detailed Architecture Analysis conducted by GE & Rolls-Royce NA

Power system:

- Electrical machines
- Power converters
- Energy Storage
- Cables

Protection system:

- Solid State Circuit Breaker
- Superconducting Fault Current Limiters

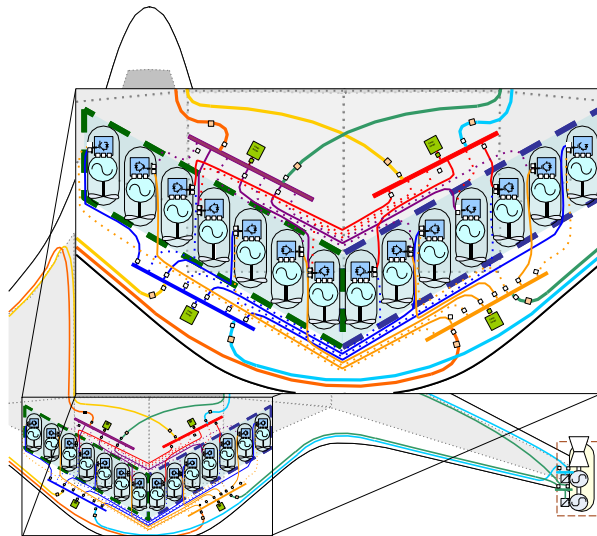

Electrical Efficiency of Cryogenic Components is Crucial

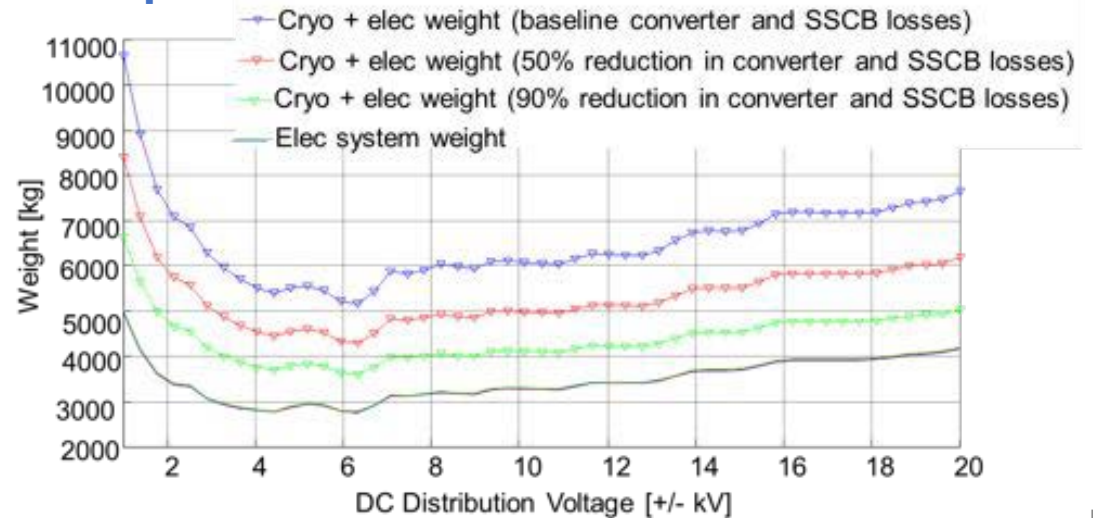



Cryogenic Power Converter Research

MTECH Cryogenic Inverter

- 2009 start SBIR program
- Demonstrated potential for > 25 kW/kg, > 99%

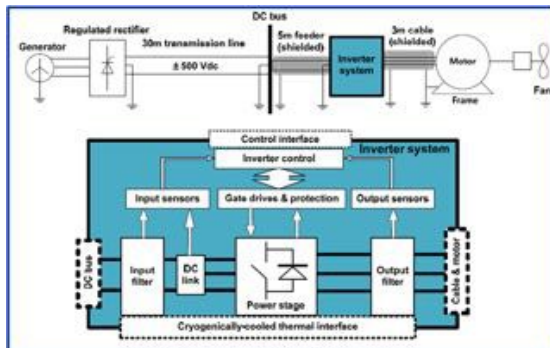
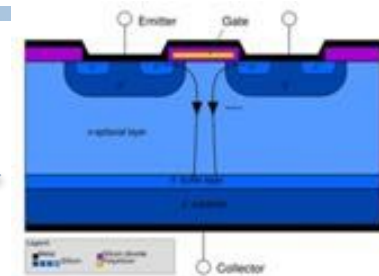

Boeing/UTK Cryogenic Inverter

- 1 MW operation with 26 kW/kg, >99% eff.
- LNG or LH2 operation
- 1000V input, 200-3000 Hz output
- 3-level Active Neutral Point Clamped Configuration
- Si CoolMOS technology (TRL 4 by 2019)

GaN Devices Offer Increased Performance

- GaN devices operate at low temps
- Results indicate potential efficiency gains
- ON resistance decreases for GaN and Si
- GaN has lower Gate to Source threshold voltage
- U of Illinois NRA 200kW inverter incl. cryo operation characterization

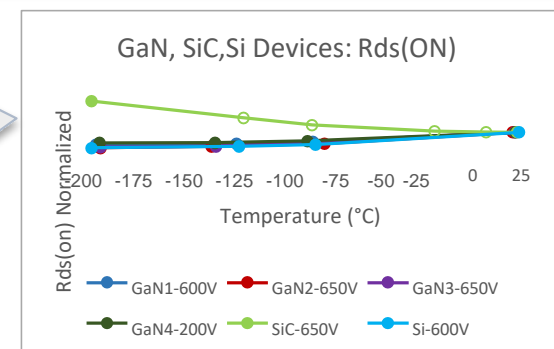



Advancing Cryocooler Technology to “Flight Weight”

Creare SBIR

- State-of-Art cryocooler specific mass is 18 kg/kW-input at 30% of Carnot
- Goal is 3 kg/kW-input at 30% of Carnot in Brayton cooler
- SBIR focus is on a high performance recuperator

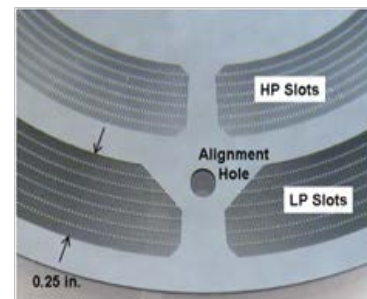
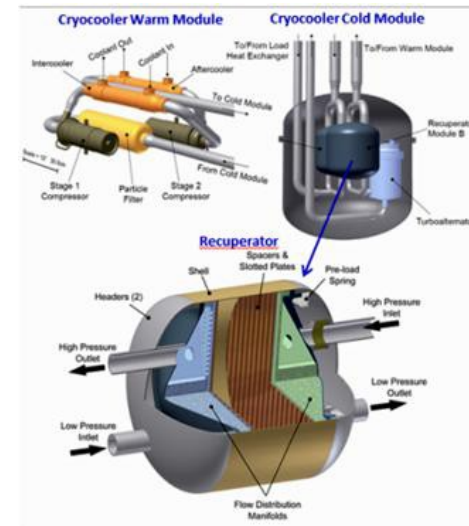

Reciprocator plate

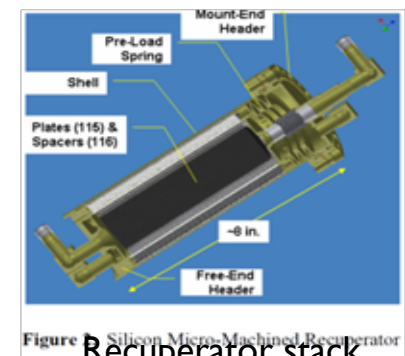
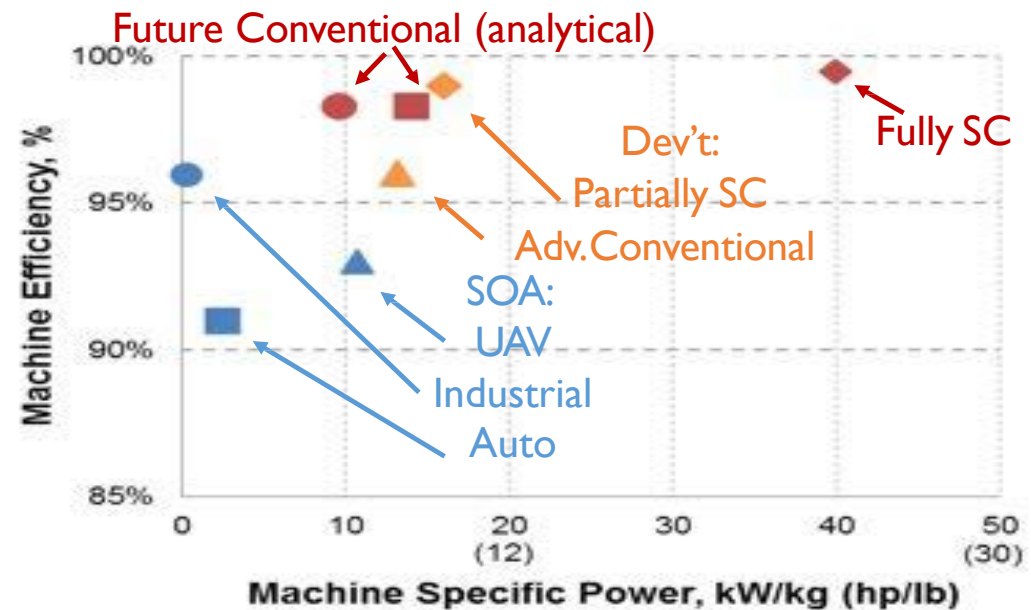
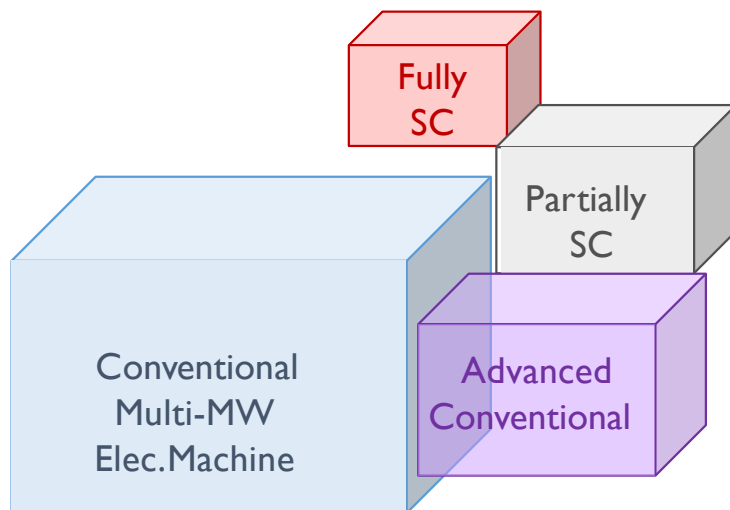

Figure 1 Silicon Micro-Machined Recuperator

The Promise of Superconducting Machines with High Specific Power and Efficiency



- Superconducting technology has a dramatic impact on electric machine volume, mass (specific power), and efficiency
- NASA studies show that increasing motor efficiency from 96% percent (Advanced Conventional) to 99% will reduce fuel burn an **additional** 2 percent and improve thermal management by a factor of 4



U of Illinois High Field, Partially Superconducting Machine



- U of Illinois, Ohio State, MagSoft, AFRL collaboration on NASA LEARN award
- Conduction-cooled, “air-core” SC machine leveraging available MRI-magnet technology
- Active magnetic shield eliminates field outside motor while maximizing “air gap” flux density
- Peak fields up to 10 Tesla
- High field SC (e.g., Nb₃Sn, YBCO)
- Address key technical feasibility questions: high field SC coils, cryogenic TMS, structural integrity, motor power density
- Specific power estimates upto 56 kW/kg for 20 MW, 6000 rpm machine with HTS windings

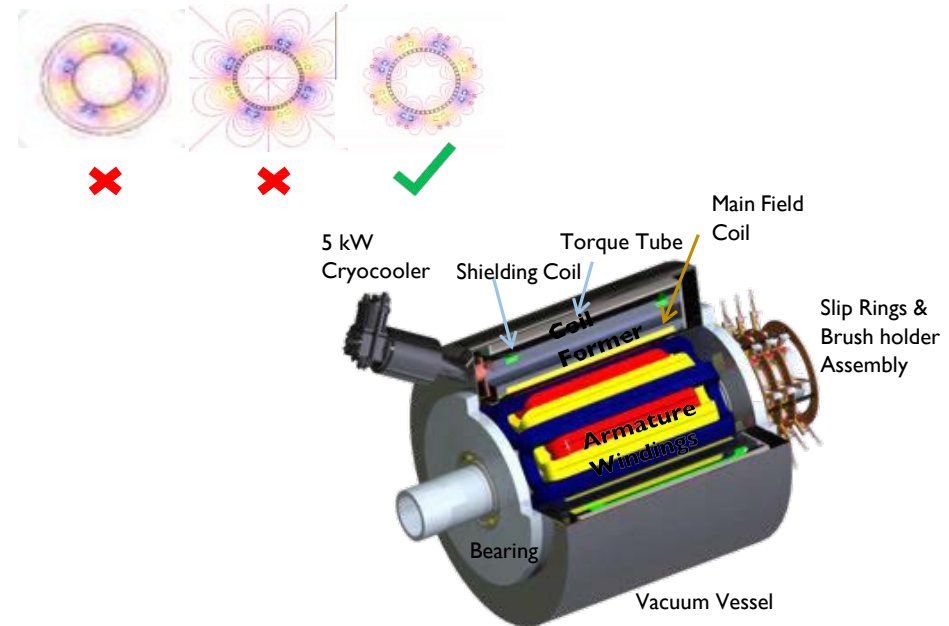

Full-size, conduction-cooled, **6 Tesla** Nb₃Sn coil demonstrated

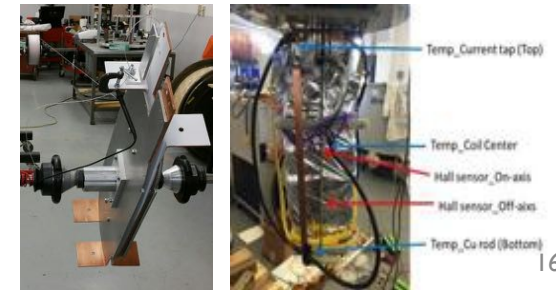

NASA High Efficiency Megawatt Motor (HEMM)



Topology

- 1.4MW wound-field synchronous motor with a stretch performance goal of 16 kW/kg and efficiency of 99%
- Conductively self-cooled, DC superconducting rotor windings combined with slotless stator
- Exceptional specific power and efficiency without external cooling weight penalty commonly attributed to SC machines

Key Features

- Uses standard aircraft cooling systems
- Direct drive at optimal turbomachinery speeds (no gearbox)
- Can be shut off if fault occurs (wound field)

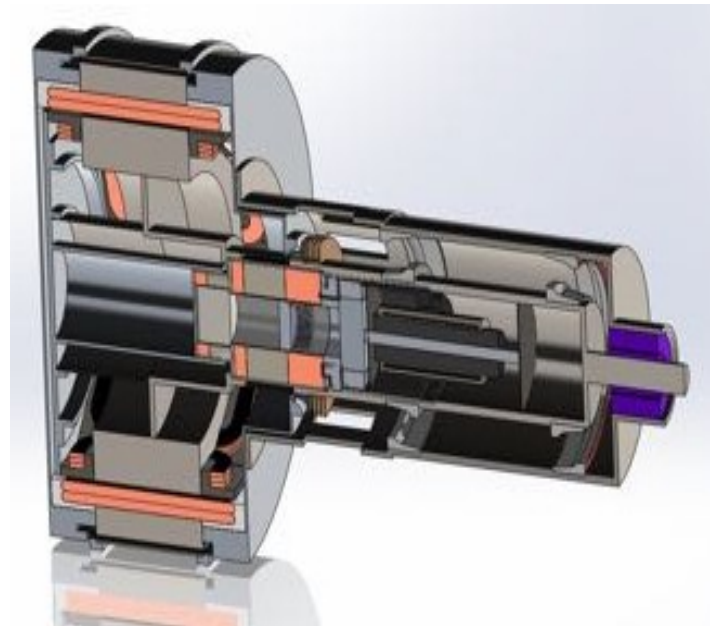

Fully SC Machines Face Loss Challenges in AC Fields



Cooling copper lowers losses, but fully SC machines have most potential

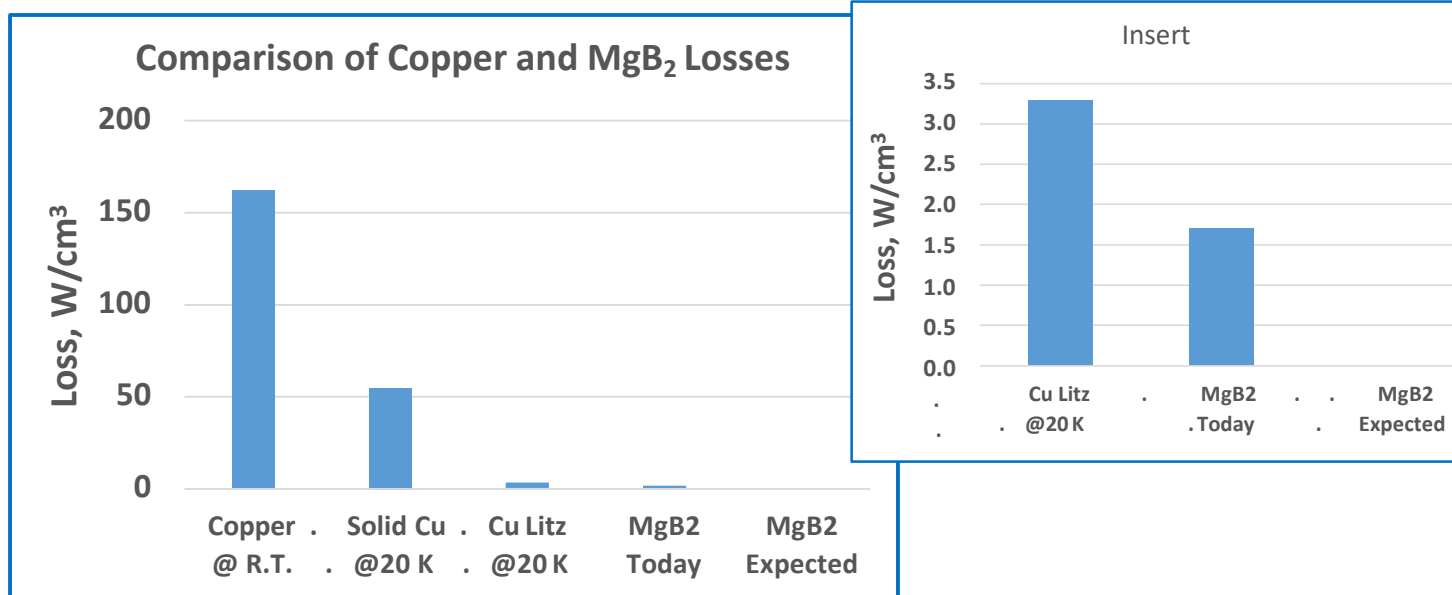

Today's MgB₂ wire has 1% of the loss of room temperature Cu in AC stators
Today's MgB₂ has half the loss of Cu Litz at 20 K
Future MgB₂ will be an order of magnitude better than Cu Litz at 20 K

Reducing Losses in AC Stator Requires Litz-like Wire



SC wire development driven by calculated (theoretical) AC losses

Solution is fine, tightly twisted filaments

- ↓ Hysteresis Loss, need fine filaments
- ↓ Coupling Loss, need tight twist
- ↓ Transport Loss, usually negligible

SBIR work by Hyper Tech Research

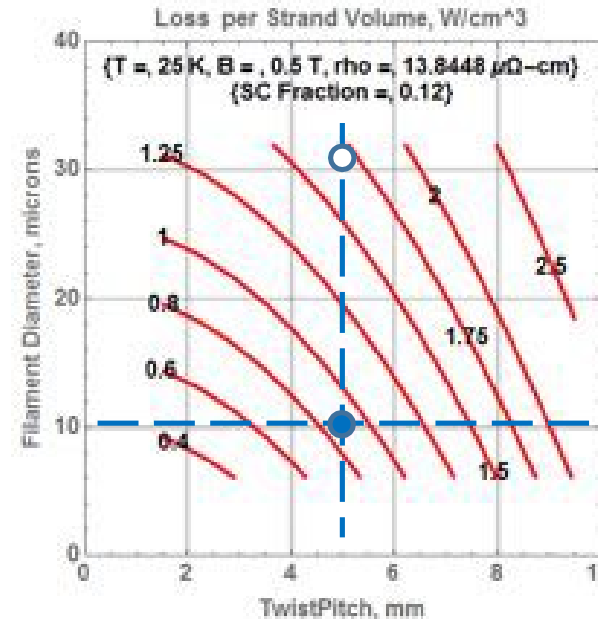

Hyper Tech Research wire configuration options developed under SBIR

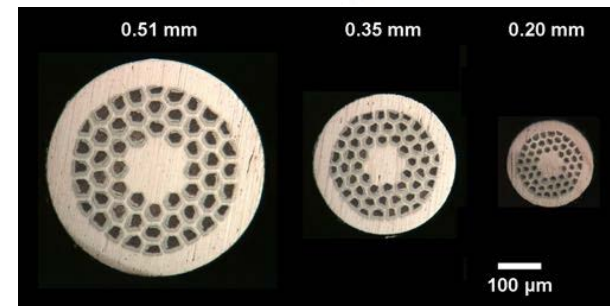

Fully Superconducting Machine Development



- Understand complex magnetic fields in real machines
- Conceptual design of fully SC machines
- Superconductor AC loss models (NRA with Applied Magnetics Lab/U of Houston), including new treatment for elliptical fields
- Construction of an AC loss facility with elliptical field capability through NRA investment at FSU Center for Advanced Power Systems

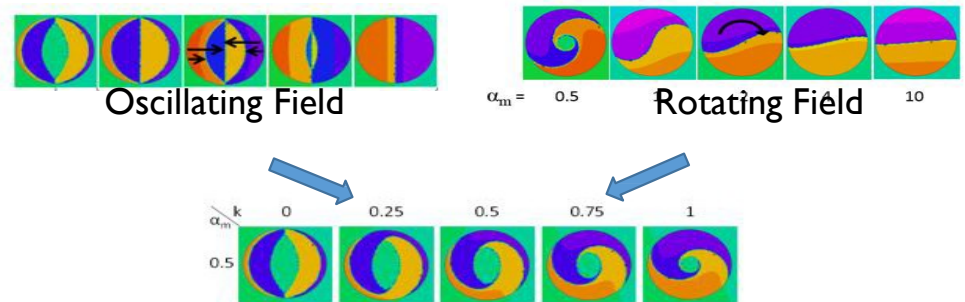
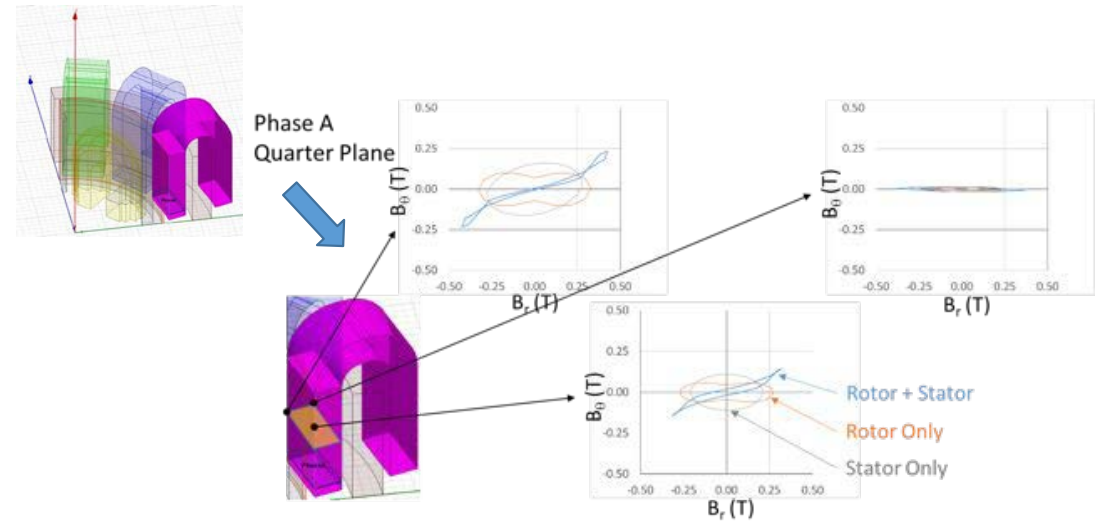

Testing Capability to Verify AC Loss in Coils at 20°K



- Measure MgB₂ superconductor losses at 20K to 30K
- Accommodate relevant coil size (~6 cm wide by 20 cm long); Magnetic field ~ 0.5 T in ~6 cm radial gap between rotor and back iron; Field frequency from 0 to 400 Hz electrical; Coil current up to 400A at up to 400 Hz frequencies
- Complements AFRL LN2 test rig by extending capability to LH2 temperature
- Facility planning complete, rotating core under construction

CoilTest Article

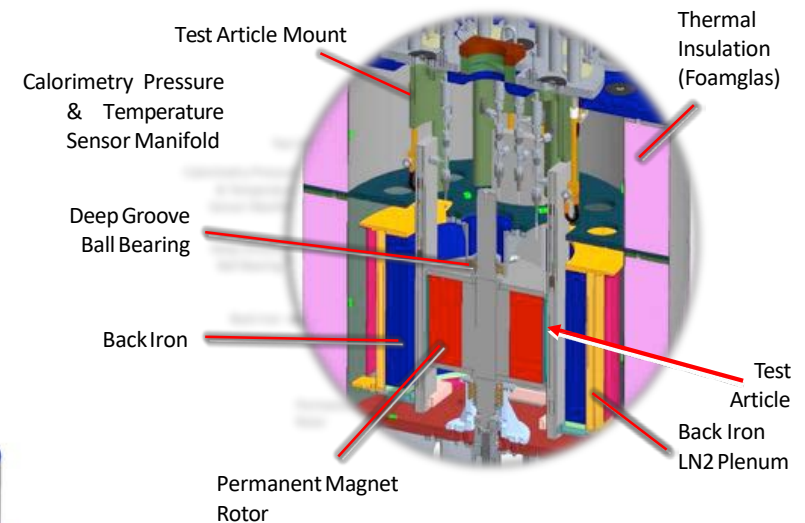
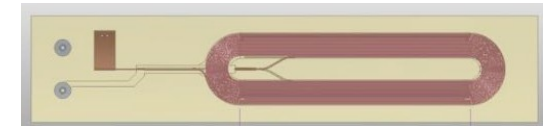

Coil testing rig with permanent magnet rotor

Full Powertrain Testing Capabilities at NEAT Facility



- Reconfigurable NASA Electric Aircraft Testbed (NEAT) being developed to support full-scale large aircraft powertrain testing for community use
- Infrastructure for up to 24 MW input power with regeneration, cryogenic fluid and fuel handling fuel, multi-MW cooling, and 120,000 feet altitude flight environment capability
- Plans to demonstrate high fidelity turbo-generation and ducted fan transient emulation, test MW-class research motors, inverters, and single- and multi-string powertrains

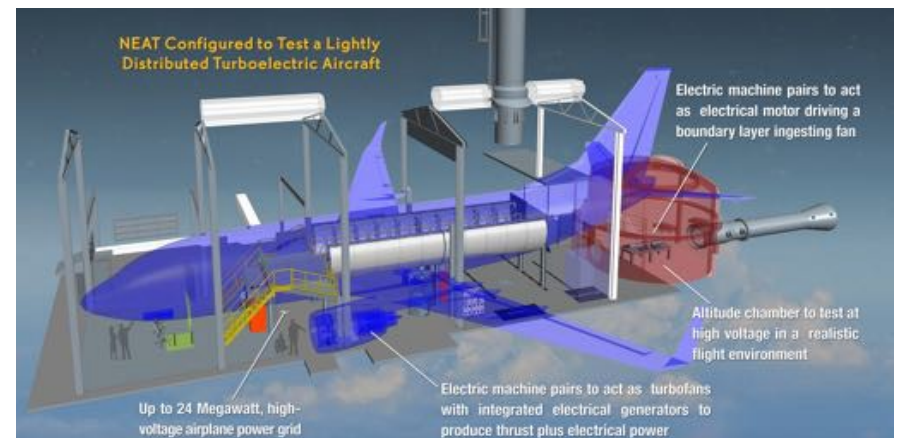

The Path Forward...



- Work both ambient temperature and superconducting solutions
- Scale up from regional jets to large single-aisle and beyond
- Advance core technologies: turbine-coupled motors, generators, power system architectures, power electronics, thermal management, flight controls
- Develop modeling/simulation tools needed
- Demonstrate technology at components, subsystems, and system level
- Viable concepts with net reduction in energy use, noise, and emissions

Exciting times ahead! Need your help!

